

TECHNICAL MANUAL

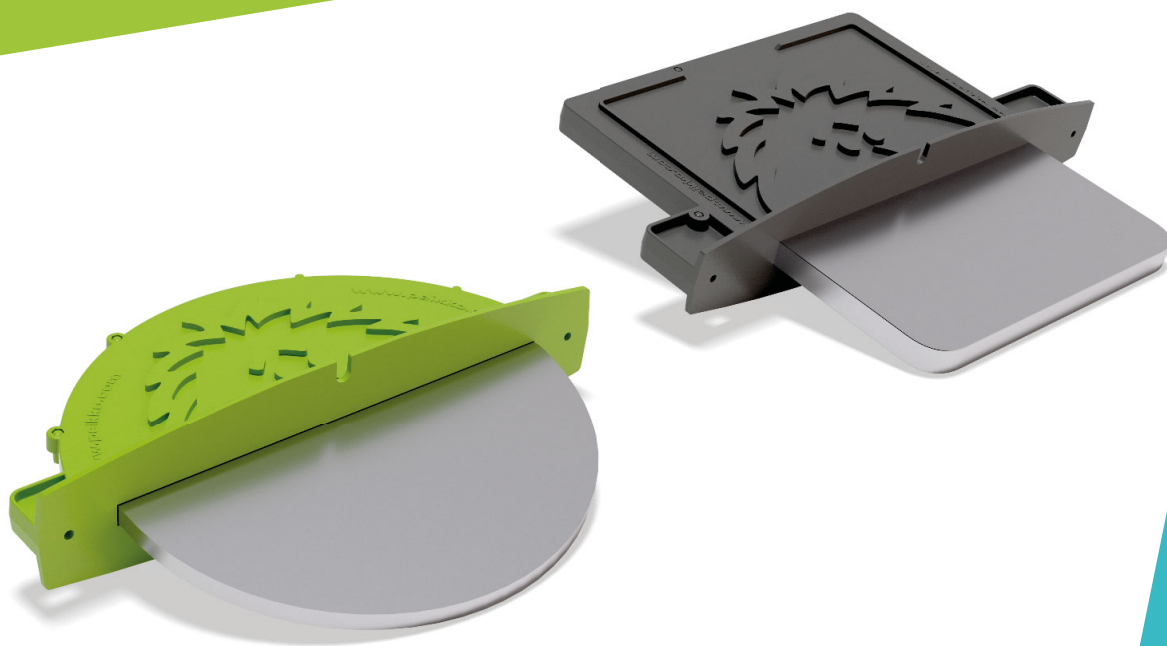

TERADOWEL and ULTRADOWEL

Reliable Dowel System for Floor Joints

Version: PEIKKO GROUP 11/2018



TERADOWEL and ULTRADOWEL

Reliable Dowel System for Floor Joints

- Dowels manufactured from high strength carbon structural steel.
- Combined with rigid high-density thin wall plastic release sleeves.
- Optimized shape of dowels for maximal bearing, bending and punching shear resistance.
- Allows all directional movement in the horizontal slab plane, minimizes vertical deflection of the slab edges.
- Easy and fast installation.

A range of efficient plate dowel load transfer systems for contraction free movement joints designed for use with traditional methods of formed joint construction with timber formwork (construction joint). Available in Plain Steel, or Hot Dip Galvanized finish, for use in interior and exterior applications.

A highly economical system with class leading load transfer capabilities. It eliminates completely the risk of slab interlock, as often seen with conventional bar dowel load transfer system applications.

TERADOWELS and ULTRADOWELS are recommended to be used for joint openings up to 20 mm wide and are suitable for construction of all types of ground level floor slabs such as jointed or jointless, ground bearing and pile supported concrete floors.

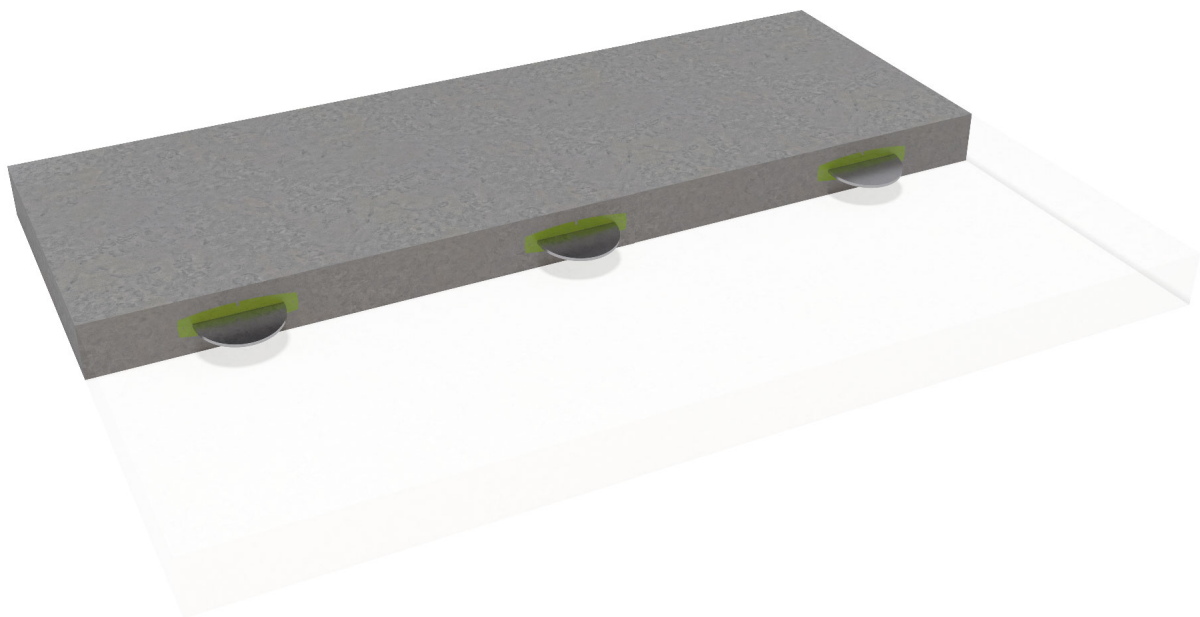
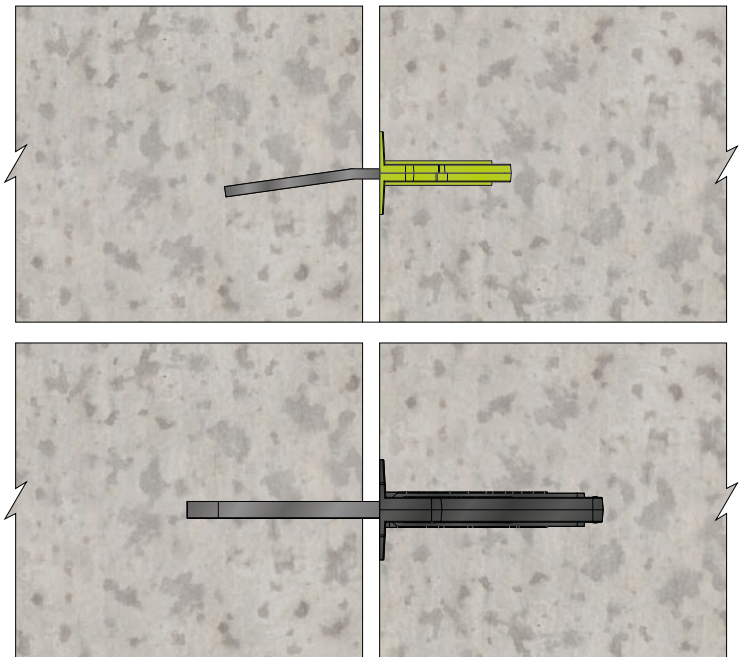

www.peikko.com

CONTENTS

| | |
|------------------------------------------|---|
| About TERADOWEL and ULTRADOWEL | 4 |
| 1. Product Properties | 4 |
| 1.1 Materials and Dimensions | 5 |
| 1.1.1 Materials | 5 |
| 1.1.2 Dimensions | 5 |
| 2. Resistances | 6 |
| Selecting TERADOWEL and ULTRADOWEL | 7 |
| Installing TERADOWEL and ULTRADOWEL..... | 8 |

About TERADOWEL and ULTRADOWEL

1. Product Properties

TERADOWEL and ULTRADOWEL are a discontinuous plate dowel load transfer system, dedicated to providing load transfer during the construction of formed free movement contraction joints. The system comprising of discrete steel plate dowel and plastic release sleeves. The sleeve contains nails for fixing to the timber formwork, and the dowel slot is covered by tape to prevent cement paste entering during pouring of the concrete. The inner bracings in the sleeve prevent deformation or collapse of the horizontal sleeve walls caused by the concrete pressure in deep slabs and allow problem free inserting of the dowel into the sleeve after formwork stripping.

A focus has been taken, during the design of the systems, on the dowel shape optimization, to minimize significant cross section reduction at higher joint openings, and to avoid areas of stress accumulation. In addition, to ensure high bending resistance, the use of advanced material selection and symmetrical design has been adopted with ULTRADOWEL, to minimize capacity loss at wide joint openings. Both TERADOWEL and ULTRADOWEL load transfer systems are integrated into all Peikko prefabricated free movement joints.

When used separately, TERADOWEL or ULTRADOWEL Sleeves are installed into position on the timber formwork at a specified distance apart, at a height of half of the slab depth, before the formwork is installed and the slab is cast. The slab containing the sleeves is poured, and after the concrete has hardened sufficiently, the timber formwork is stripped. TERADOWELS or ULTRADOWELS are then inserted to the slots of the cast in sleeves, and the second pour is performed.

TERADOWEL and ULTRADOWELS permit the free slab movements, caused by drying shrinkage and thermal variations in both longitudinal and perpendicular directions of the slab plane, thereby eliminating the principle cause of shrinkage cracks at the joint, and minimizing vertical displacement of the slabs. The sleeves permit 10 mm longitudinal movement of the dowels in either direction.

The limiting factor of load transfer in most cases, is the punching shear resistance of the concrete, these resistances can be found in section 2. It is recommended that no more than 50% of the applied load should be transferred by the load transfer system, the slab itself should be designed to carry the rest of the load.

Figure 1. Load transfer.

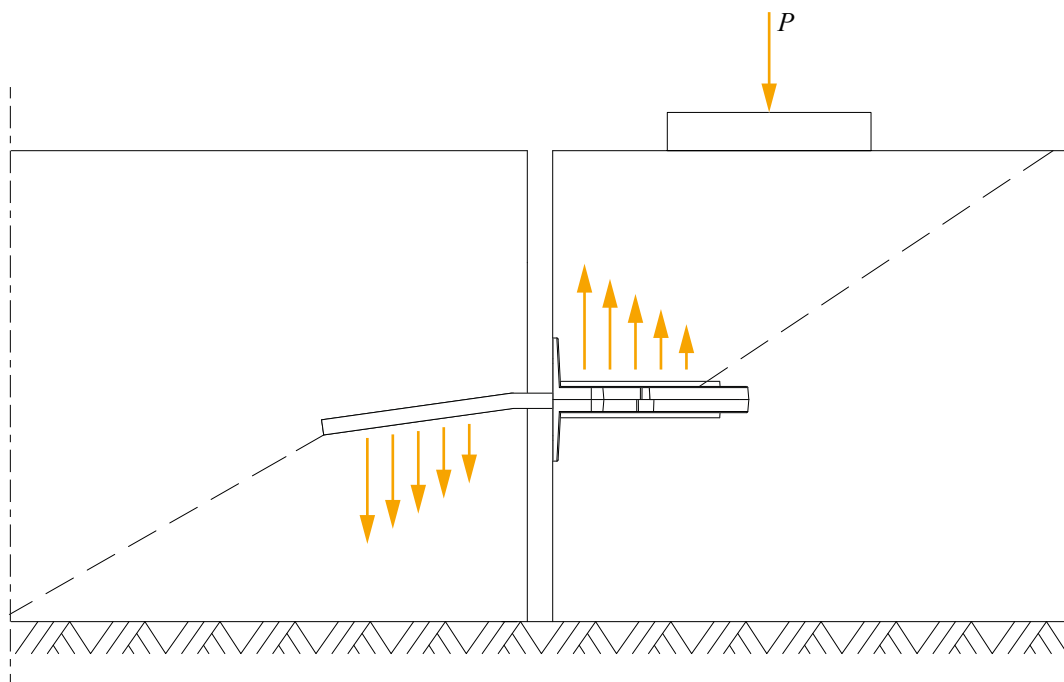

1.1 Materials and Dimensions

1.1.1 Materials

Table 1. Materials of TERADOWEL and ULTRADOWEL.

| Dowel | | Sleeve | |
|----------------------------------|----------------|--------------------------------------|-----------------|
| Version | Material | Version | Material, Color |
| TERADOWEL Circular TDC-6 | S355J2 + N | TERADOWEL Sleeve Circular TDS-C6 | ABS, Green |
| TERADOWEL Circular TDC-6 HDG | S355J2 + N HDG | TERADOWEL Sleeve Circular TDS-C6 | ABS, Green |
| ULTRADOWEL Rectangular UDR-8 | S700MC | ULTRADOWEL Sleeve Rectangular UDS-R8 | ABS, Gray |
| ULTRADOWEL Rectangular UDR-8 HDG | S700MC HDG | ULTRADOWEL Sleeve Rectangular UDS-R8 | ABS, Gray |

HDG = Hot dip galvanized. Standard for black steel EN 10025.

1.1.2 Dimensions

Table 2. Dimensions [mm] of TERADOWEL and ULTRADOWEL.

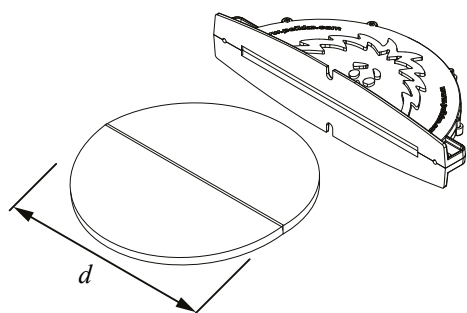

| | |
|--------------------------|-------------------------------|
| Dowel Type | TERADOWEL Circular 6 mm TDC-6 |
| Thickness | 6 mm |
| Diameter d | 150 mm |
| Sleeve Color | Green |
| Adjustable Joint Opening | 0 ~ 15 mm |

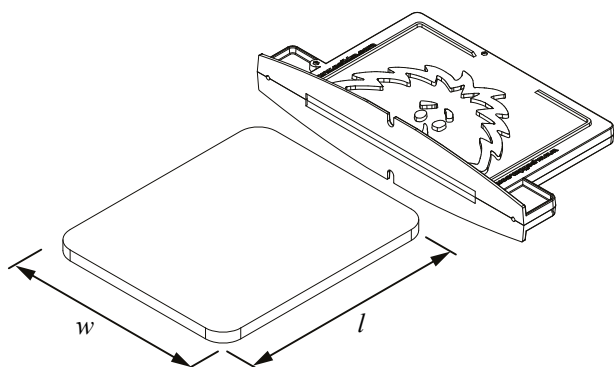

| | |
|--------------------------|-----------------------------------|
| Dowel Type | ULTRADOWEL Rectangular 8 mm UDR-8 |
| Thickness | 8 mm |
| Dimensions $w \times l$ | 145 mm x 175 mm |
| Sleeve Color | Gray |
| Adjustable Joint Opening | 15 ~ 20 mm |

2. Resistances

Resistances of the TERADOWEL and ULTRADOWEL are determined according to UK Concrete Society TR34.4 published August 2013. All calculated design resistances are for single plate dowels.

Table 3. Design resistances of dowels in shear and bearing/bending [kN] according TR34.4 for C32/40.

| Dowel Type | Joint Opening x | Shear Psh | P Max Plate |
|------------|-----------------|-----------|-------------|
| TDC-6 | 15 mm | 145.0 | 41.4 |
| UDR-8 | 20 mm | 381.3 | 93.8 |

Table 4. Design punching shear resistance [kN] of TDC-6 according TR34.4 for 15 mm joint opening.

| Slab Thickness | Punching Pp C25/30 | Punching Pp C28/35 | Punching Pp C30/37 | Punching Pp C32/40 | Punching Pp C35/45 |
|----------------|--------------------|--------------------|--------------------|--------------------|--------------------|
| 100 mm | 9.8 | 10.4 | 10.7 | 11.1 | 11.6 |
| 150 mm | 15.6 | 16.5 | 17.1 | 17.7 | 18.5 |
| 200 mm | 22.5 | 23.8 | 24.7 | 25.5 | 26.6 |
| 250 mm | 30.4 | 32.2 | 33.4 | 34.4 | 36.0 |

Table 5. Design punching shear resistance [kN] of UDR-8 according TR34.4 for 20 mm joint opening.

| Slab Thickness | Punching Pp C25/30 | Punching Pp C28/35 | Punching Pp C30/37 | Punching Pp C32/40 | Punching Pp C35/45 |
|----------------|--------------------|--------------------|--------------------|--------------------|--------------------|
| 100 mm | 11.4 | 12.1 | 12.5 | 12.9 | 13.5 |
| 150 mm | 17.6 | 18.6 | 19.3 | 19.9 | 20.8 |
| 200 mm | 24.8 | 26.3 | 27.2 | 28.1 | 29.4 |
| 250 mm | 33.1 | 35.0 | 36.2 | 37.4 | 39.1 |

The punching shear resistances are calculated for plain concrete without any kind of additional reinforcement, and according TR34.4 should be used also for steel and macro-synthetic fiber reinforced concrete.

If resistances for other joint openings or concrete grades are needed, please contact Peikko Technical Support.

Selecting TERADOWEL and ULTRADOWEL

TERADOWEL and ULTRADOWEL are selected according to following criteria:

- **Designed joint opening.** For joint openings of up to 15 mm wide, we recommend TERADOWEL TDC-6. For joint openings from 15 to 20 mm wide ULTRADOWEL UDR-8 is recommended. Whereas for pile supported slabs, we would only recommend the use of TDR-8.
- **Dowel spacing c/c.** The center to center dowel spacing should be as determined by the structural engineer for specific load conditions. For general conditions is recommended to use 500 ~ 600 mm spacing. Spacing can be reduced if necessary, but it is not recommended to use smaller spacing than listed in Table 6 below, otherwise punching shear resistance of the dowels may be reduced.
- **Environment.** For internal floors we would suggest the basic plain steel dowels. For external applications and where corrosion resistance is required, it is recommended to use HDG (Hot Dipped Galvanised) dowels.
- **20 mm designed joint opening.** This refers generally to 50 x 50 m slab size limiting dimensions of jointed floors, and a 35 x 35 m of jointless floors. A wider joint opening is possible, but resistances must be reduced accordingly. The UDR-8 dowel works reliably up to joint openings of 30 mm wide, however it is not recommended to use such wide joint openings with non-armored formed joints.
- **Joint aspect ratio.** Individual slabs should ideally have an aspect ratio of 1:1, this may not always be possible, but the ratio should never exceed 1:1.5.

A further recommendation is to assist prevention of restraint, by separation of the fixed elements from the slab, with the use of flexible compressible foam filler, with a thickness of at least 20 mm, also by avoiding re-entrant corners and avoiding point loads at joints.

Table 6. Minimal recommended dowel center to center spacing [mm].

| Slab Depth [mm] | 100 mm | 150 mm | 200 mm | 250 mm | 300 mm | 350 mm | 400 mm |
|--------------------------------|--------|--------|--------|--------|--------|--------|--------|
| Minimal dowel c/c spacing [mm] | 300 mm | 375 mm | 450 mm | 525 mm | 600 mm | 675 mm | 750 mm |

Installing TERADOWEL and ULTRADOWEL

1. Mark a horizontal line on the formwork at the level of half slab thickness ($h/2$) and mark the required center to center spacing of the sleeves along this line.
2. Nail the sleeves firmly through the nail holes at the marked locations on the formwork.
3. Pour concrete as normal around dowel sleeves paying attention to the fill around the sleeves. All plate type dowels require adequate compaction with a Poker Vibrator around them, to eliminate the possibility of air entrapment below the sleeve.
4. After concrete has hardened adequately and the formwork removed, the nails should be flattened and the dowels inserted into the sleeve pockets. The dowels should be inserted fully into the sleeves. The second slab can be then be poured, against the face of the first, and the exposed portion of the steel dowels.

Install the sleeves to the formwork.



Insert the dowels to the sleeves.

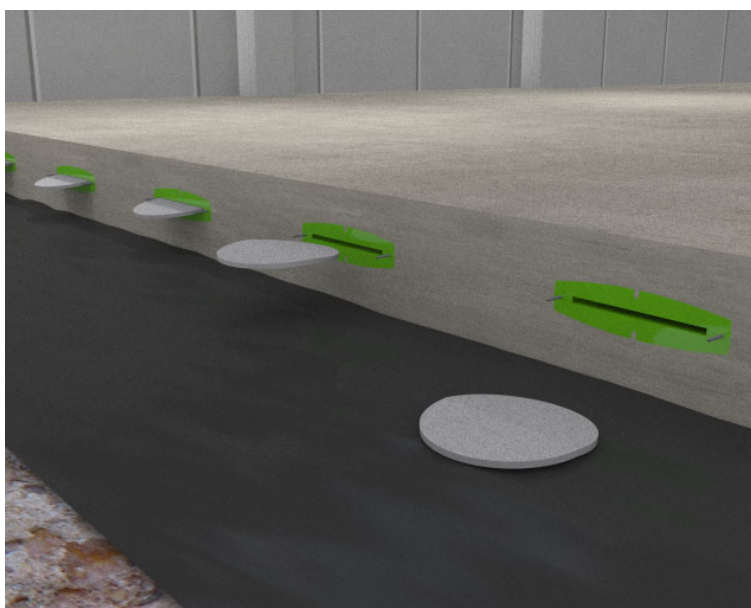



Technical Manual Revisions

Version: PEIKKO GROUP 11/2018. Revision: 002

- Resistance tables updated
- Illustration updates for clarity
- Updated layout to latest branding

Version: PEIKKO GROUP 06/2014. Revision: 001*

- New cover design for 2018 added

Resources

DESIGN TOOLS

Use our powerful software every day to make your work faster, easier, and more reliable. Peikko design tools include design software, 3D components for modeling programs, installation instructions, technical manuals, and product approvals of Peikko's products.

peikko.com/design-tools

TECHNICAL SUPPORT

Our technical support teams around the world are available to assist you with all of your questions regarding design, installation etc.

peikko.com/technical-support

APPROVALS

Approvals, certificates, and documents related to CE-marking (DoP, DoC) can be found on our websites under each products' product page.

peikko.com/products

EPDS AND MANAGEMENT SYSTEM CERTIFICATES

Environmental Product Declarations and management system certificates can be found at the quality section of our websites.

peikko.com/qehs

COMPANY WITH
MANAGEMENT SYSTEM
CERTIFIED BY DNV
ISO 9001 • ISO 14001
ISO 45001